

**Detail Valve Box Installation**

Note: Valve box shall not transmit shock or stress to the valve

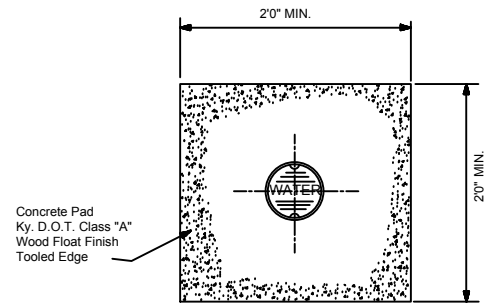

**PLAN**

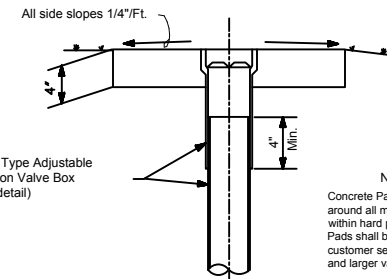

Screw Type Adjustable Cast Iron Valve Box (See detail)

**NOTES**

Concrete Pads shall be constructed around all main line valve boxes except within hard paved areas. Concrete Pads shall be constructed around customer service line valve boxes 3" and larger valves.

**ELEVATION**

REVISION	BY	DATE
1	MPS	8/25/13
2	MPS	9/22/13

N. KY. WATER DISTRICT  
VALVE BOX AND  
VALVE PAD DETAIL

DRAWN BY:  
SAR

APPROVED:  
*[Signature]*

DATE:  
2/1/2021

STANDARD  
DRAWING NO:  
105