

**EARTH CUTS
TRENCH DETAIL**

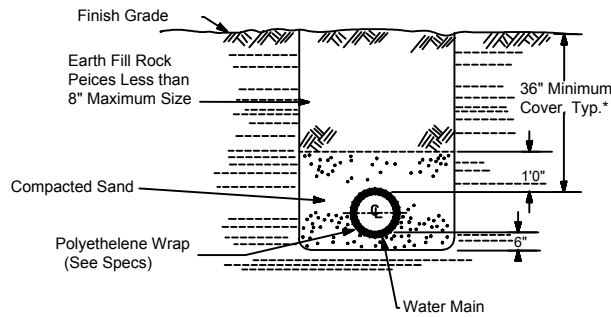

**ROCK CUTS
& UNSTABLE SUBGRADE
TRENCH DETAIL**

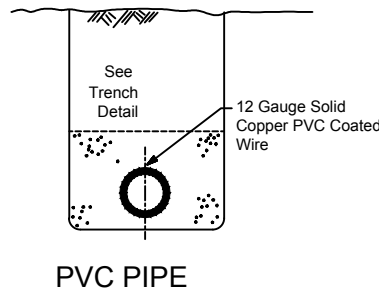

PVC PIPE

ALTERNATE TO BE USED ONLY ON APPROVAL
BY THE DISTRICT

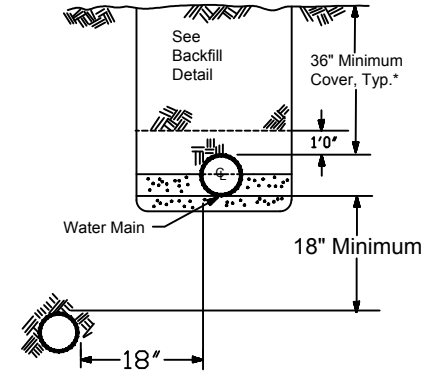

Water Main must be located a minimum of 10 feet lateral distance from any existing or future sewer lines or manholes, or as shown in the above alternate.

**WATER MAIN PARALLELING
SEWER MAIN**

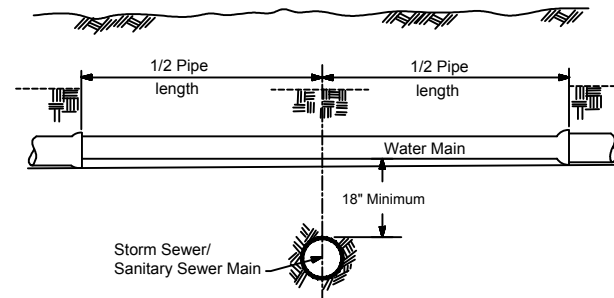

WATER MAIN CROSSING SEWER

SUBDIVISION CONSTRUCTION

* Unless Otherwise Noted

REVISION	BY	DATE
1	MPS	11/5/93
2		
3		
4		
5		
6		
7		
8		
9		
10		
11		
12		
13		
14		
15		
16		
17		
18		
19		
20		
21		
22		
23		
24		
25		
26		
27		
28		
29		
30		
31		
32		
33		
34		
35		
36		
37		
38		
39		
40		
41		
42		
43		
44		
45		
46		
47		
48		
49		
50		
51		
52		
53		
54		
55		
56		
57		
58		
59		
60		
61		
62		
63		
64		
65		
66		
67		
68		
69		
70		
71		
72		
73		
74		
75		
76		
77		
78		
79		
80		
81		
82		
83		
84		
85		
86		
87		
88		
89		
90		
91		
92		
93		
94		
95		
96		
97		
98		
99		
100		

N. KY. WATER DISTRICT
TYPICAL PIPELINE TRENCH
DETAIL

DRAWN BY:
SAR

APPROVED:
[Signature]

DATE:
2/1/2021

STANDARD
DRAWING NO:
103